

Product Specifications



1269 Principale
Saint-Agapit, Quebec
G0S 1Z0
Phone: 1-800-463-7461
Fax: 1-800-463-6167
www.sawpinc.com
Email: sawp@total.net

♻️ Printed on Recycled Paper

Table of Contents

| | |
|--|-------|
| Product Coding | 2 |
| Ordering Information | 3 |
| Door Construction | 4 |
| Models | 5 |
| Stile And Rail Options (mortise and tenon) | 6 |
| Mitered Door Options | 7 |
| Panel Raise | 8 |
| Outside Edge Detail (mortise and tenon) | 9 |
| Mortise and Tenon Detail | 10-11 |
| Mitered Detail | 12-17 |
| Frames | 18 |
| Applied Moldings | 19 |
| Crown Moldings | 20 |
| Crown Moldings with Base | 21 |
| Decorative Moldings | 22 |
| Accessories | 23 |

Order form available on the last page

Product Coding

A - BB - C - D - EEE - FFF - GGG - HHH

A - Product Category (1 digit)

P - Door
C - Frame
D - Drawer Front
M - Molding
A - Accessory
V - Valance
T - Drawer Box

C - Description (1 digit)

0 - Raised Panel
1 - Flat Panel
2 - Mullion Frame
3 - Open Frame
4 - MDF Panel
5 - Double Design Raised Panel
6 - Double Design Flat Panel
7 - Double Design Mullion Frame
8 - Double Design Open Frame
9 - Double Design MDF Panel

E - Stiles and Rails Profile (up to 4 digits)

S01, S02, etc.... (see pages 6-7)

G - Edge Detail (up to 3 digits)

E01, E02, etc... (see page 9)

B - Design (2 digits)

11 - Mortise and Tenon + Applied Molding
12 - Square
13 - Regular Cathedral
14 - Arch
15 - Low Cathedral
16 - Fancy Cathedral
22 - Shaker Plus
44 - Mitered + Applied Molding
45 - Mitered

D - Wood Species (1 digit)

| | |
|-----------------|-------------------|
| 0 - Red Oak | 5 - MDF |
| 1 - Hard Maple | 6 - Soft Maple |
| 2 - Cherry | 7 - Miscellaneous |
| 3 - Birch | 8 - Hickory |
| 4 - Knotty Pine | 9 - Alder |

F - Panel Raise (up to 3 digits)

P1, P2, etc... (see page 8)

Note: When product category is C (frame door—no center panel), this changes to G, followed by the number of lites. (i.e. G1 = 1 lite, G6 = 6 lites, etc...)

H - Applied Molding (up to 3 digits)

AM1, AM2, etc... (see page 19)

Example: P1401-S01-P2-E8

This would be an Arched Maple Raised Panel door with S01 stiles and rails, P2 Panel Raise and E8 Edge Detail.

Ordering Information

Mortise and Tenon - Raised Panel

- When ordering, specify model, type of wood, framing bead, panel raise and edge detail (ex: 1200-Oak-S01-P5-E3).
- Model 1200 - available in S01, S02, S03, S05, S07, S10 framing beads.
- Model 1300, 1400, 1500, 1600, 1350, 1450, 1550 available in S01, S02, S05, S06 framing beads.
- Grain runs vertical on doors and horizontal on drawer fronts with the exception of panel raise P8 and P13 which always run vertical.
- Unless specified, raised panel drawer fronts have reduced top and bottom rails.
- All doors over 44" high will have a center horizontal crossrail, or will not be under warranty.

Mortise and Tenon - Flat Panel

- When ordering, specify model, type of wood, framing bead and edge detail (ex: 1210-Oak-S03-E16).
- Model 1210 - available in S01, S02, S03, S04, S05, S07, S10 framing beads.
- Model 1310, 1410, 1510, 1610, 1360, 1460, 1560 available in S01, S02, S05, S06 framing beads.
- Grain runs vertical on doors and horizontal on drawer fronts.
- Unless specified, flat panel drawer fronts have full top and bottom rails.
- All doors over 44" high will have a center horizontal crossrail, or will not be under warranty.

Mitered - Raised Panel

- When ordering, specify model, type of wood, framing bead and panel raise (ex: 4500-Oak-S450-P9).
- Available with all mitered framing beads from S300 to S590.
- Grain runs vertical on doors and horizontal on drawer fronts with the exception of panel raise P8 and P13 which always run vertical.
- Crossrails are not available on mitered doors (no warranty on doors over 44" high).

Mitered - Flat Panel

- When ordering, specify model, type of wood and framing bead (ex: 4510-Oak-S570).
- Available with all mitered framing beads from S300 to S590.
- Grain runs vertical on doors and horizontal on drawer fronts.
- Crossrails are not available on mitered doors (no warranty on doors over 44" high).

Door Construction

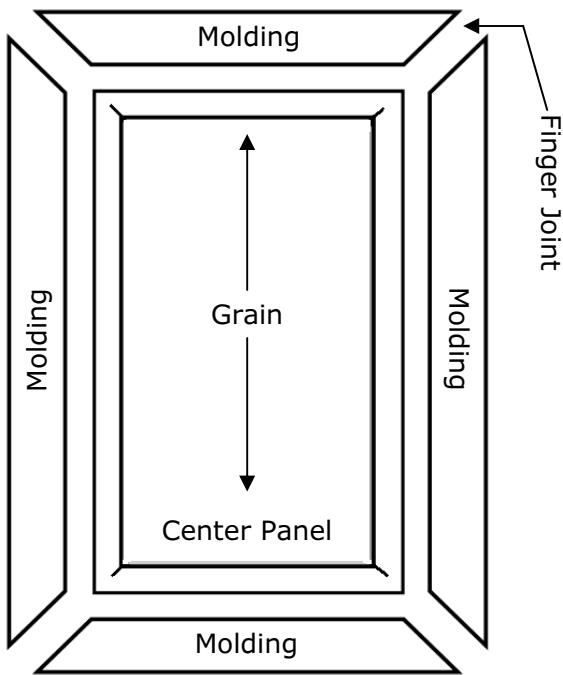
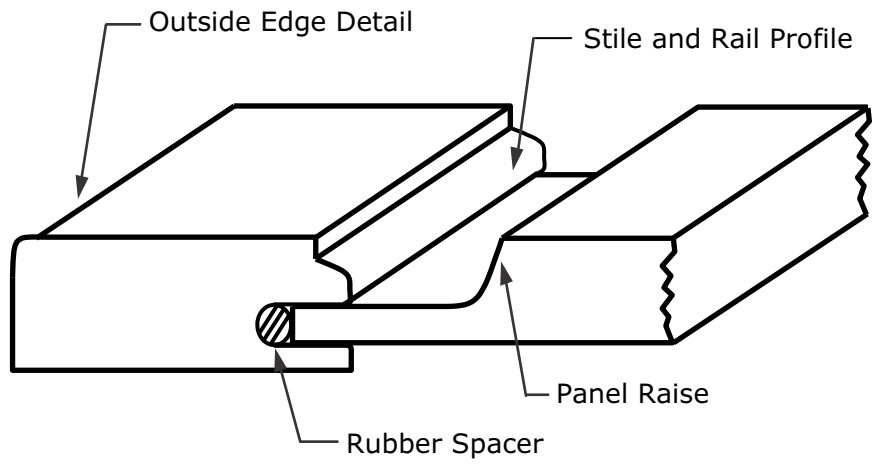

Mitered Door

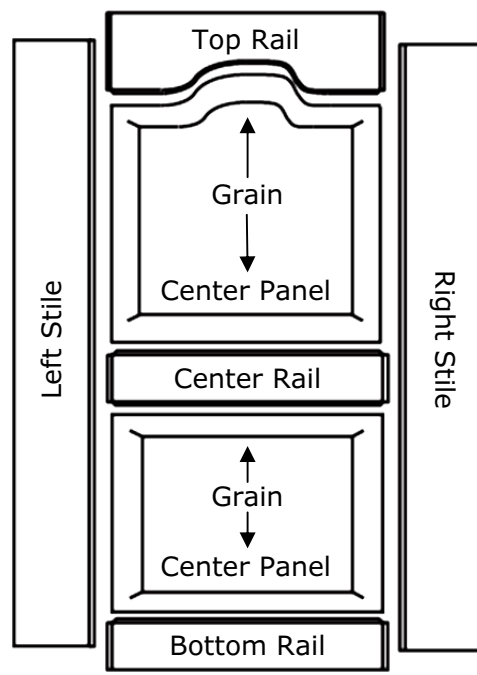

Mortise and Tenon Door

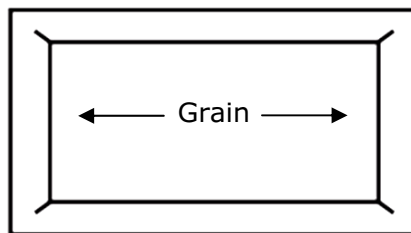

Typical Drawer front

Models

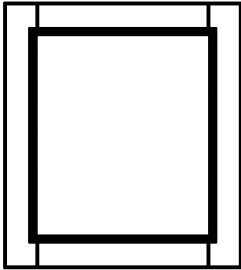

1100 Raised Panel
1110 Flat Panel
(Applied Molding)

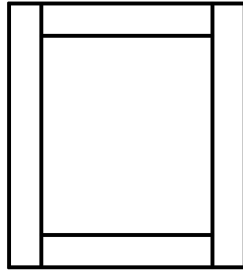

1200 Raised Panel
1210 Flat Panel
(Square)

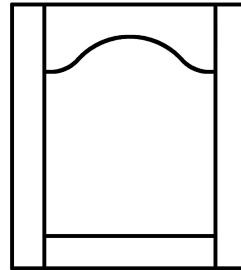

1300 Raised Panel
1310 Flat Panel
(Cathedral)

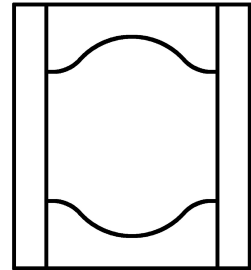

1350 Raised Panel
1360 Flat Panel
(Double Cathedral)

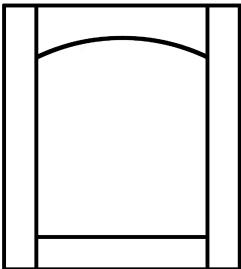

1400 Raised Panel
1410 Flat Panel
(Arch)

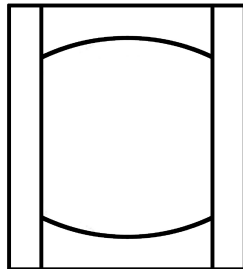

1450 Raised Panel
1460 Flat Panel
(Double Arch)

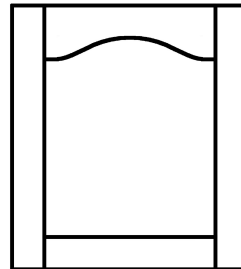

1500 Raised Panel
1510 Flat Panel
(Low Cathedral)

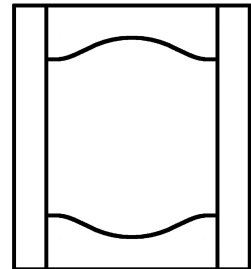

1550 Raised Panel
1560 Flat Panel
(Double Low Cathedral)

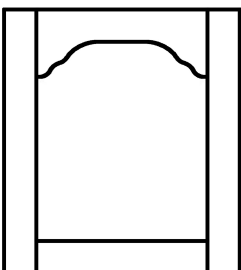

1600 Raised Panel
1610 Flat Panel
(Fancy Cathedral)

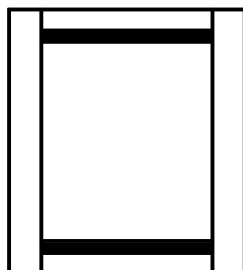

2200 Raised Panel
2210 Flat Panel
(Shaker Plus)

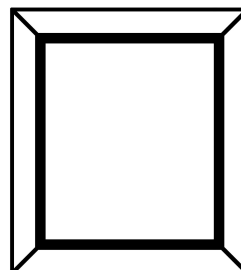

4400 Raised Panel
4410 Flat Panel
(Applied Molding)

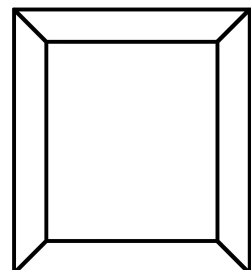

4500 Raised Panel
4510 Flat Panel
(Mitered)

For mortise and tenon stile and rail options, see page 6
For mitered door options, see page 7

Stile and Rail Options (mortise and tenon)



S01

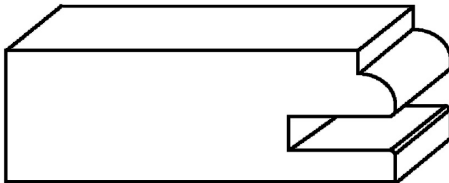

S02*

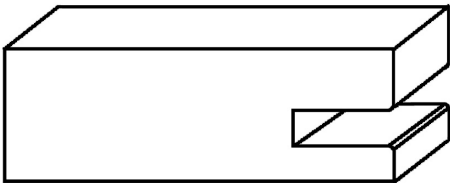

S03*

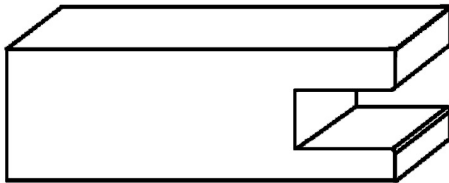

S04

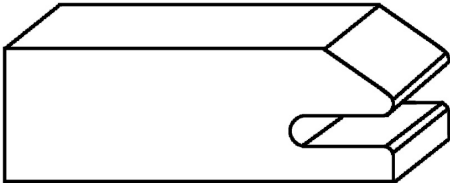

S05

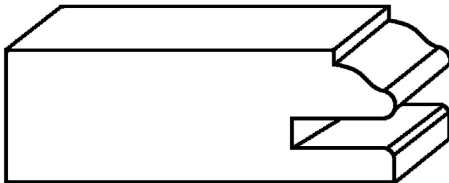

S06*

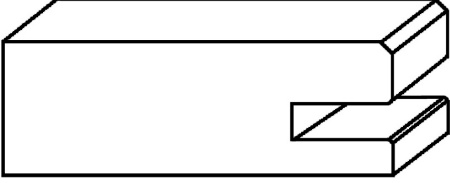

S07

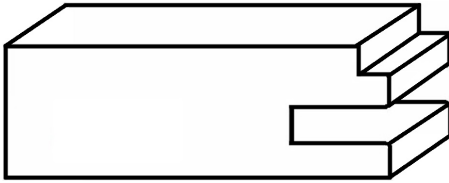

S17

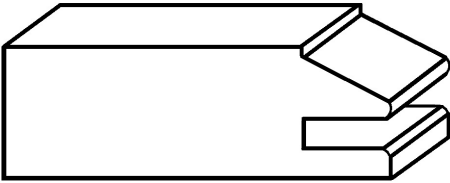

S20

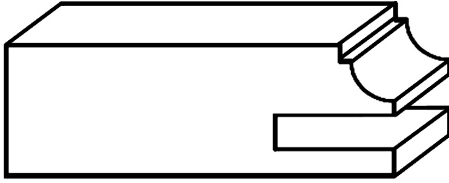

S23

* Standard
Details on pages 10-11

Mitered Door Options



S300

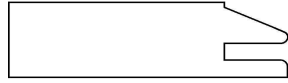

S305



S320



S321*

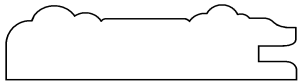

S325

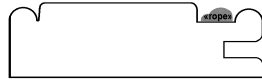

S330



S335

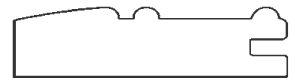

S340

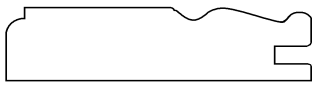

S345

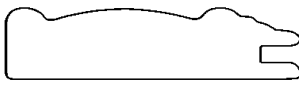

S350



S355



S365



S370*



S380



S390

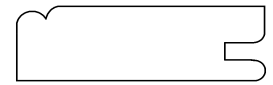

S400



S410



S420



S425



S435



S440*

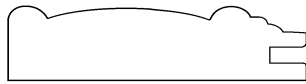

S450*



S460*

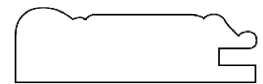

S470

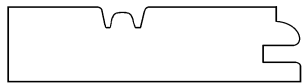

S480



S490



S510



S520



S525



S530

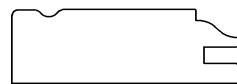

S540



S550



S570



S580

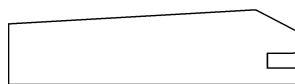

S585*



S605

* Standard
 Details on pages 12-17

Panel Raise

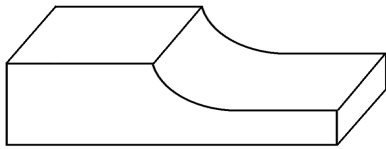

P1*

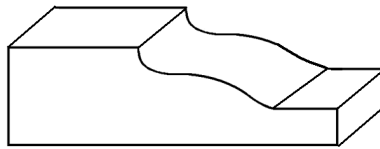

P2*

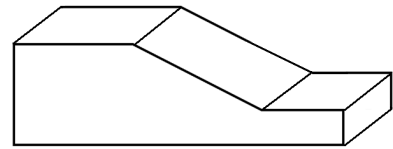

P3

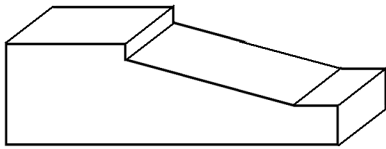

P4*

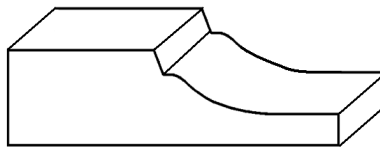

P5*

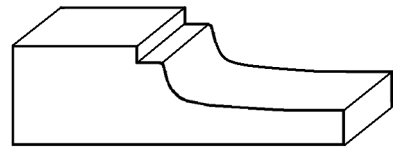

P6

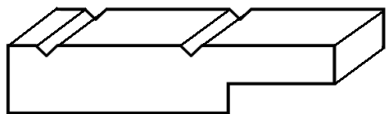

P8

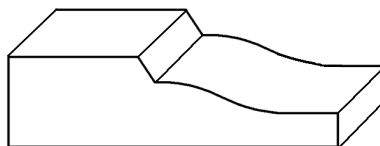

P9

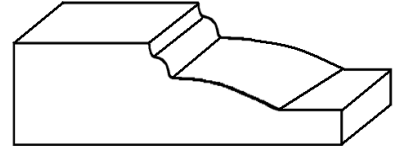

P10



P11

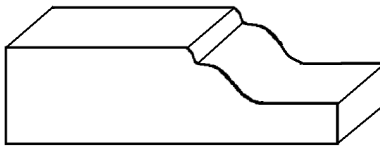

P12

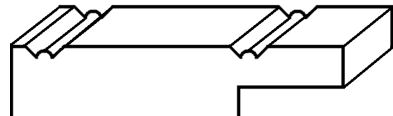

P13

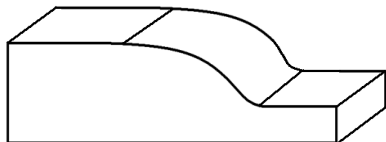

P17

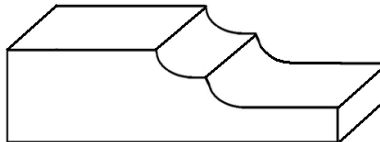

P19

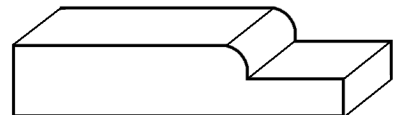

P20

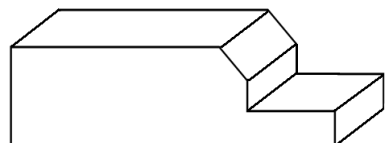

P21

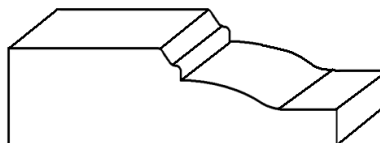

P23



P25*

* Standard

Center panels are 5/8" thick except P8, P11, P13, P25 at 3/8" thick and P20 at 7/16" thick

Outside Edge Detail (mortise and tenon)

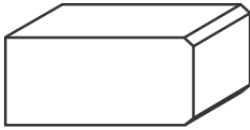

E1

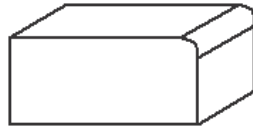

E2

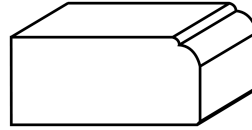

E3

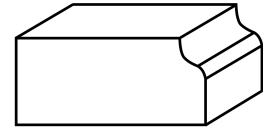

E4

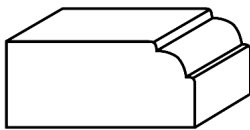

E5

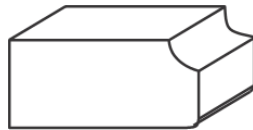

E6

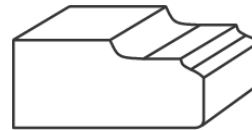

E7*

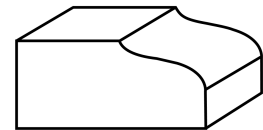

E8**

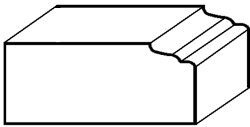

E9

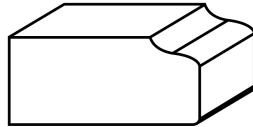

E10

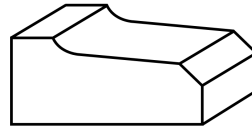

E11*

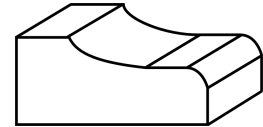

E12*

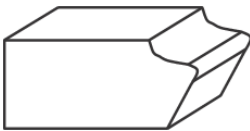

E14

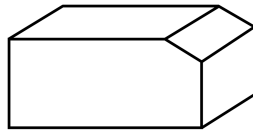

E15



E16

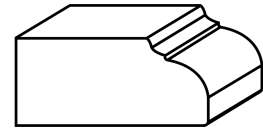

E17**

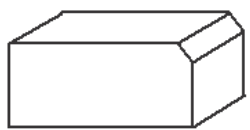

E18

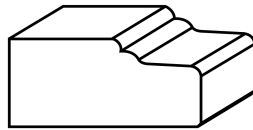

E19**

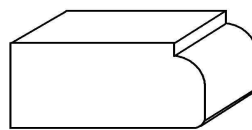

E21

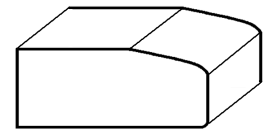

E22

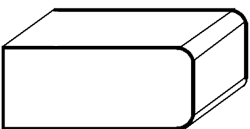

E23

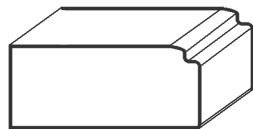

E25

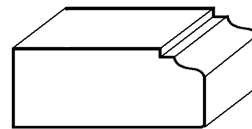

E26

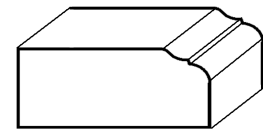

E28

* Available on slab drawer fronts only

** Adjustment of hinge hole depth may be necessary

Mortise and Tenon Detail

Door

Drawer Front

Mullion

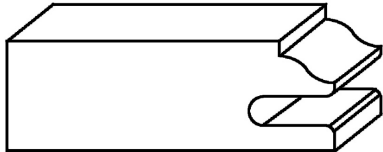

S01 - 2 1/4"

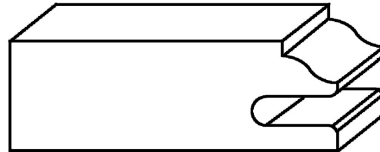

S01D - 2 1/4" *

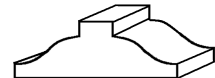

G01 - 1 1/16"

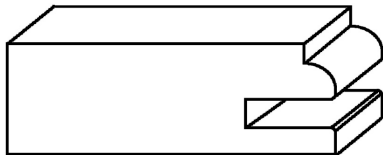

S02 - 2 1/4"

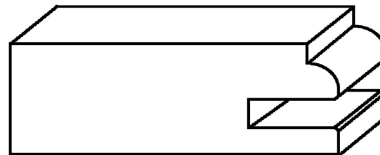

S02D - 2 1/4" *



G02 - 15/16"

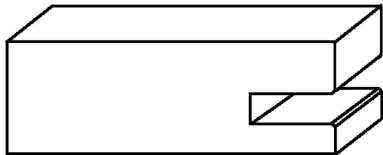

S03 - 2 1/4"

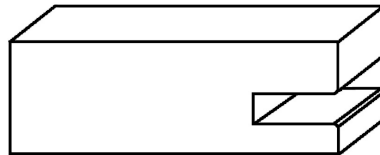

S03D - 2 1/4" *

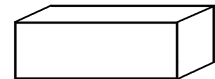

G03 - 1 1/16"

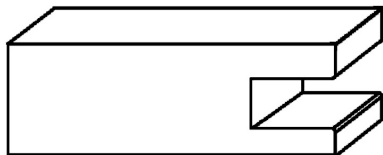

S04 - 2 1/4"

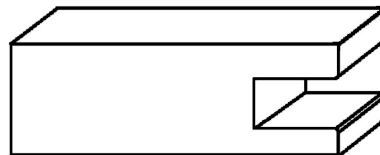

S04D - 2 1/4"

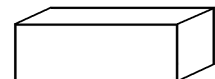

G03 - 1 1/16"

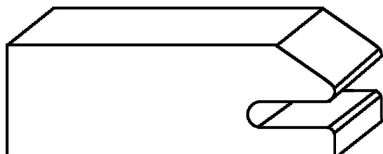

S05 - 2 1/4"

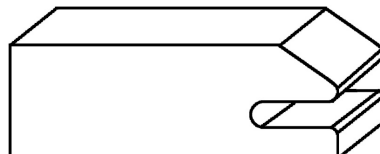

S05D - 2 1/4" *

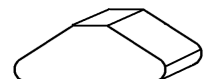

G05 - 1"

* Stiles are 2 1/4", flat panel fronts have 2 1/4" rails and raised panel fronts have 1 3/4" rails

Mortise and Tenon Detail

Door

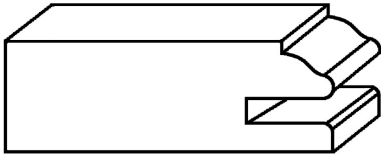

S06 - 2 1/4"

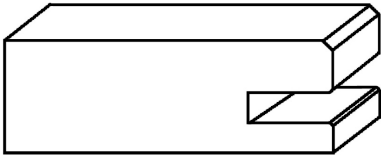

S07 - 2 1/4"

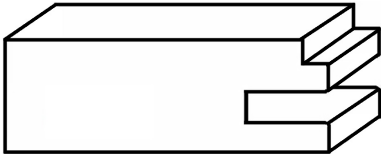

S17 - 2 1/4"

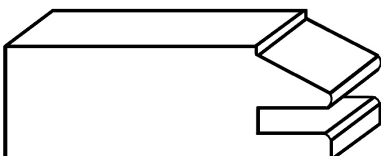

S20 - 2 1/4"

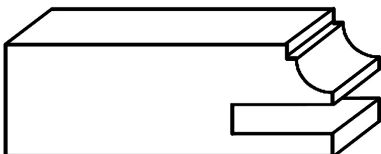

S23 - 2 1/4"

Drawer Front

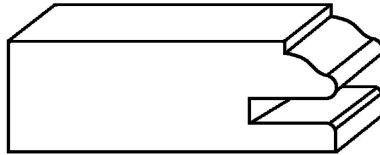

S06D - 2 1/4" *

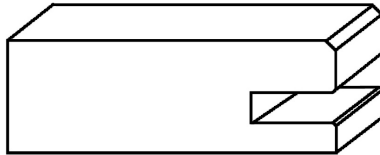

S07D - 2 1/4" *

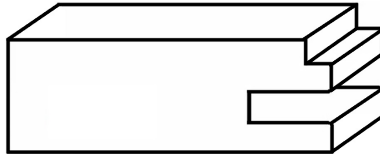

S17D - 2 1/4" *

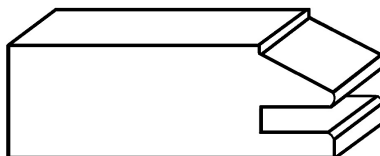

S20D - 2 1/4" *

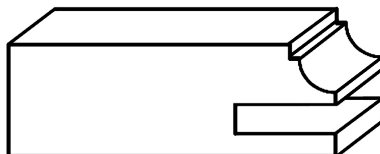

S23D - 2 1/4" *

Mullion

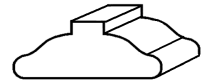

G06 - 15/16"

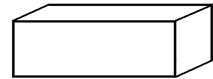

G03 - 1 1/16"



G03 - 1 1/16"



G20 - 1 1/2"



G23 - 1 1/8"

* Stiles are 2 1/4", flat panel fronts have 2 1/4" rails and raised panel fronts have 1 3/4" rails

Mitered Detail

Door

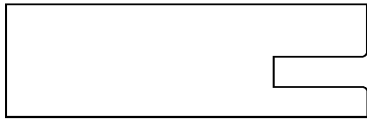

S300 - 2 3/8"

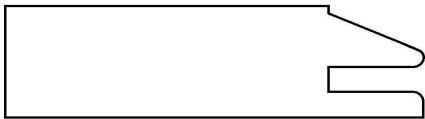

S305 - 2 3/4"



S320 - 2 1/2"



S321 - 2 7/8"



S325 - 2 7/8"

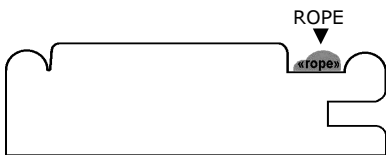

S330 - 2 1/2"

Drawer Front

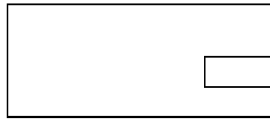

S300D - 1 3/4"

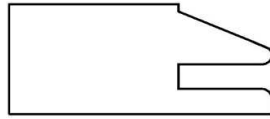

S305D - 1 3/4"

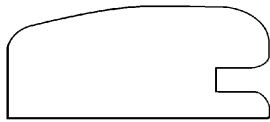

S320D - 1 3/4"

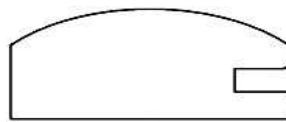

S321D - 1 7/8"



S325D - 1 9/16"

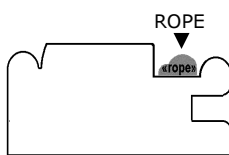

S330D - 1 1/2"

Mullion

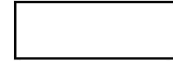

G03 - 1 1/16"



G20 - 1 1/2"

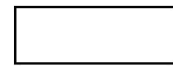

G03 - 1 1/16"









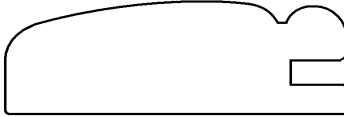
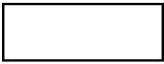

N/A

N/A

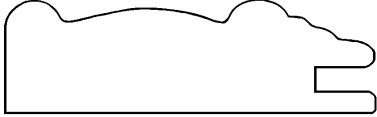

G03 - 1 1/16"

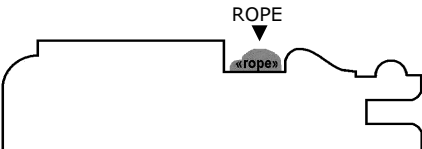
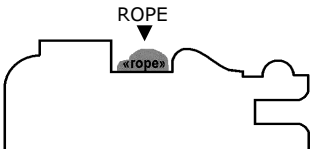
Mitered Detail

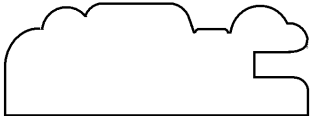
| <u>Door</u> | <u>Drawer Front</u> | <u>Mullion</u> |
|--|---|---|
|  S335 - 2 1/4" |  S335D - 2 1/4" |  G03 - 1 1/16" |
|  S340 - 2 3/4" |  S340D - 1 7/8" | N/A |
|  S345 - 3" |  S345D - 2" |  G03 - 1 1/16" |
|  S350 - 2 15/16" |  S350D - 2 7/16" |  G350 - 1 1/16" |
|  S355 - 2 3/4" |  S355D - 2" | N/A |
|  S365 - 2 1/2" |  S365D - 2" | N/A |

Mitered Detail

Door

Drawer Front

Mullion

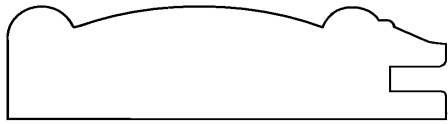

S370 - 2 7/8"

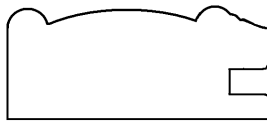

S370D - 1 7/8"

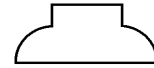

G02 - 15/16"



S380 - 2 5/8"



S380D - 2"

N/A

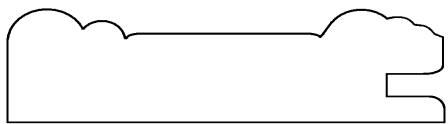

S390 - 2 7/8"

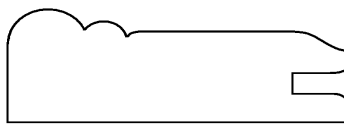

S390D - 2 3/16"

N/A

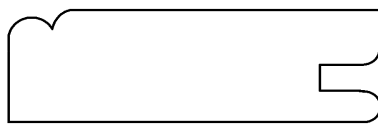

S400 - 2 7/16"

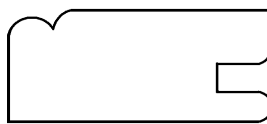

S400D - 1 3/4"

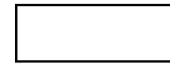

G03 - 1 1/16"



S410 - 2 3/8"

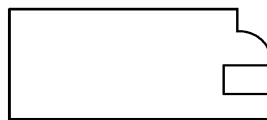

S410D - 1 3/4"

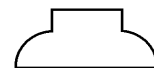

G02 - 15/16"

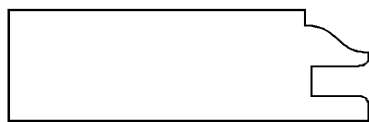

S420 - 2 3/8"

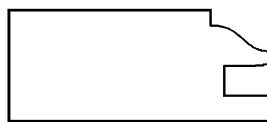

S420D - 1 3/4"

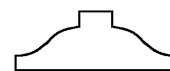

G01 - 1 1/16"

Mitered Detail

Door

Drawer Front

Mullion



S425 - 2 3/8"



S425D - 1 3/4"



G06 - 15/16"



S435 - 2 3/8"

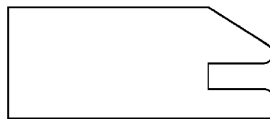

S435D - 1 3/4"

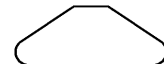

G05 - 1"



S440 - 2 7/16"



S440D - 1 3/4"

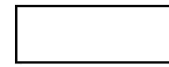

G03 - 1 1/16"

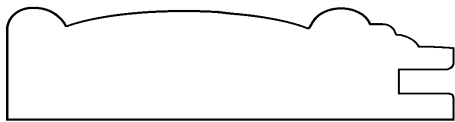

S450 - 3"

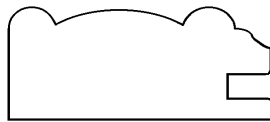

S450D - 1 3/4"

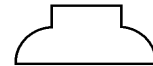

G02 - 15/16"



S460 - 2 1/4"



S460D - 2"



G03 - 1 1/16"

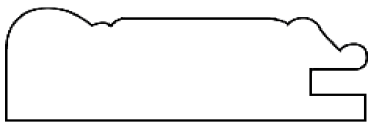

S470 - 2 3/8"

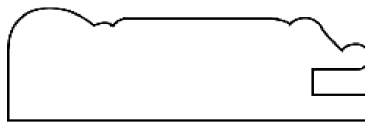

S470D - 2 3/8"

N/A

Mitered Detail

Door

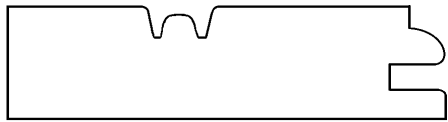

S480 - 2 7/8"



S490 - 2 1/4"

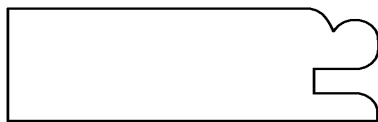

S510 - 2 7/16"



S520 - 2 7/8"

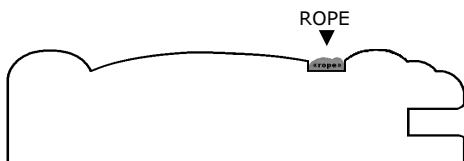

S525 - 3"



S530 - 3"

Drawer Front

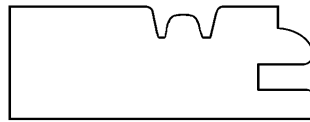

S480D - 2"

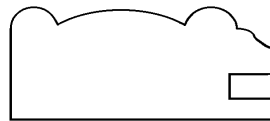

S490D - 1 3/4"

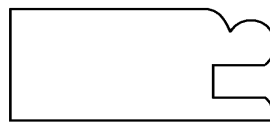

S510D - 1 3/4"



S520D - 1 7/8"

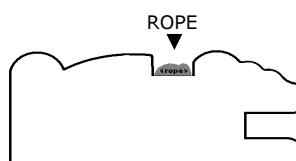

S525D - 1 15/16"

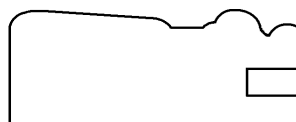

S530D - 1 15/16"

Mullion

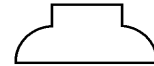

G02 - 15/16"



G02 - 15/16"

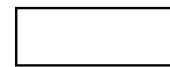

G03 - 1 1/16"

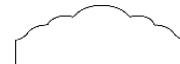

G520 - 1 1/8"













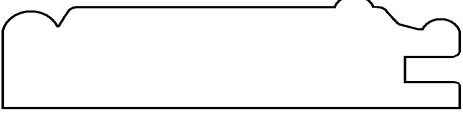

G525 - 1 3/16"

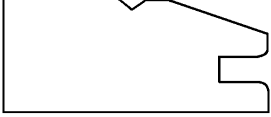

G03 - 1 1/16"

Mitered Detail

| <u>Door</u> | <u>Drawer Front</u> | <u>Mullion</u> |
|--|--|---|
|  S540 - 2 1/4" |  S540D - 1 3/4" |  G01 - 1 1/16" |
|  S550 - 3" |  S550D - 2.5/16" |  G03 - 1 1/16" |
|  S570 - 2 7/8" |  S570D - 1 13/16" |  G02 - 15/16" |
|  S580 - 2 5/8" |  S580D - 1 3/4" | N/A |
|  S585 - 3" |  S585D - 1 7/8" | N/A |
|  S605 - 2 1/4" |  S605D - 1 3/4" | N/A |

Frames

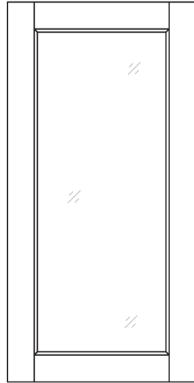

Open frame

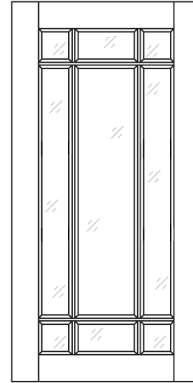

9 lite offset**

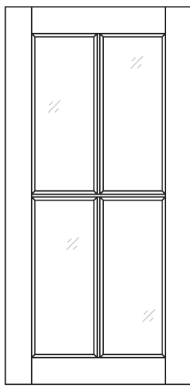

4 lite

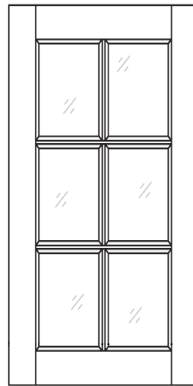

6 lite

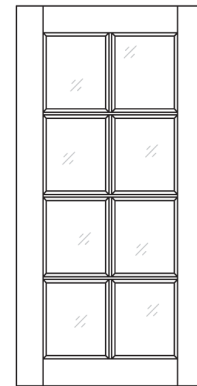

8 lite

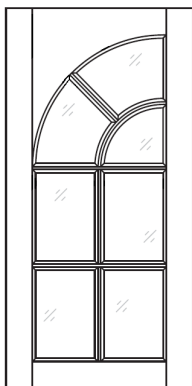

7 lite left*

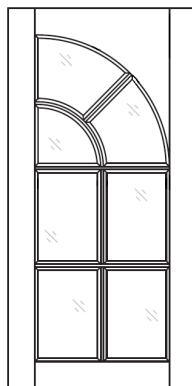

7 lite right*

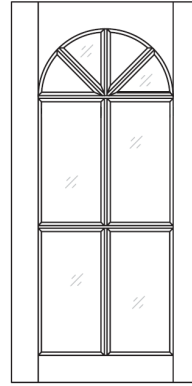

8 lite round*

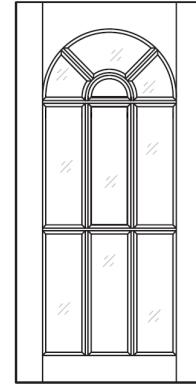

10 lite round*

* Only available with the S01 or S02 stile and rail.

** Only available with models that have a square design.

Applied Moldings

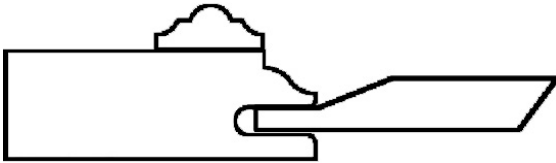

H: 5/16"
W: 3/4"



AM1 is available on all flat surface framing beads, using any center panel

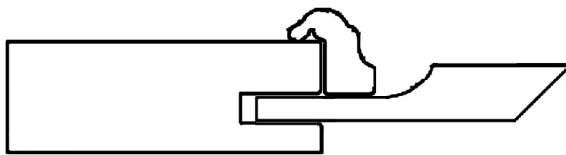

H: 5/8"
W: 5/8"



AM2 is available on S03 and S300 framing bead, using P1, P8, P11, P12, P13, P25 or 1/4" flat center panel

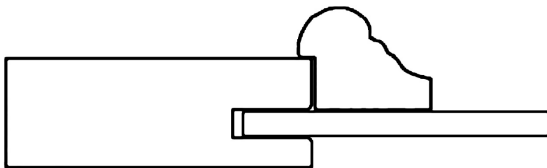

H: 3/4"
W: 1"

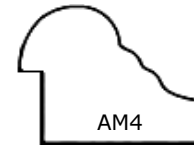

AM4 is available on S03 or S300 framing bead, using P8, P11, P13, P25 or 1/4" flat center panel

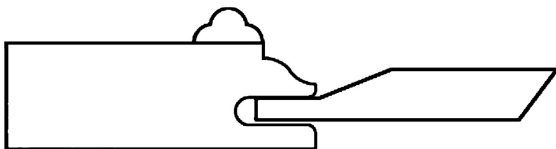

H: 1/4"
W: 1/2"



AM5 is available on all flat surface framing beads, using any center panel

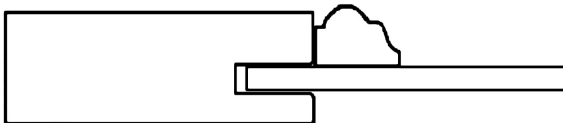

H: 7/16"
W: 5/8"



AM6 is available on S03 or S300 framing bead, using P8, P11, P13, P25 or 1/4" flat center panel

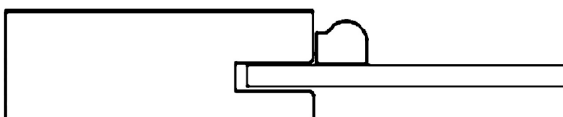

H: 5/16"
W: 3/8"



AM7 is available on S03 or S300 framing bead, using P8, P11, P13, P25 or 1/4" flat center panel

Crown Moldings



M124
H: 1 5/8"
W: 1 5/8"

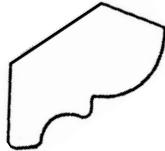

M149
H: 1 1/8"
W: 1 1/16"

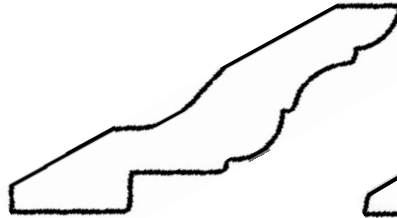

M152
H: 1 15/16"
W: 3 5/8"



M131
H: 1 3/4"
W: 3 3/16"

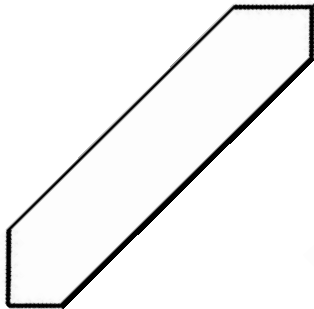

M136
H: 2 1/2"
W: 2 1/2"

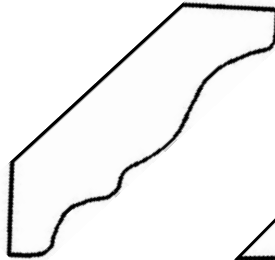

M133
H: 2"
W: 2"

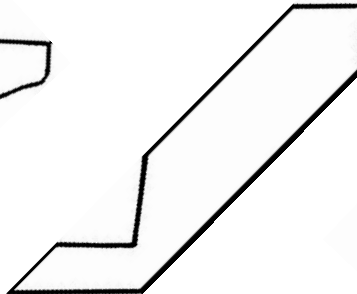

M134
H: 2 3/8"
W: 2 15/16"

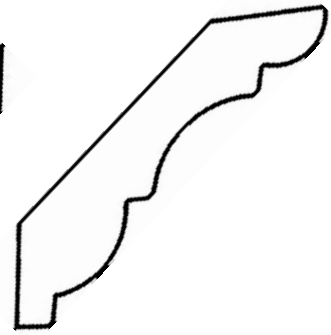

M168
H: 2 9/16"
W: 2 3/8"

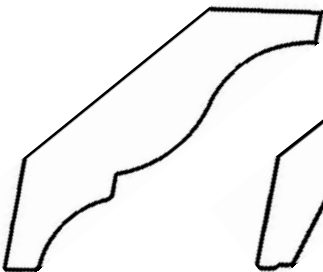

M158
H: 2 5/16"
W: 2 5/16"

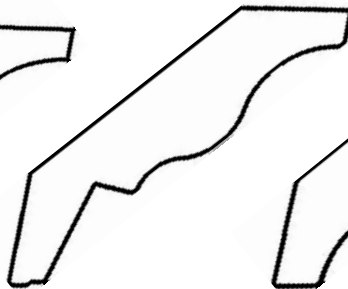

M164
H: 2 1/2"
W: 2 3/8"

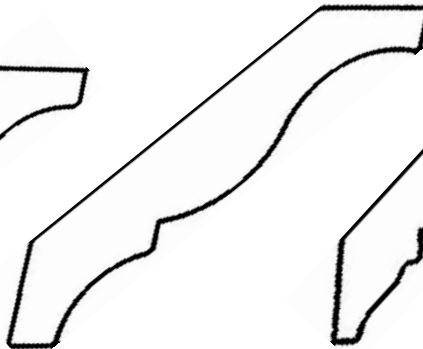

M159
H: 3"
W: 3"

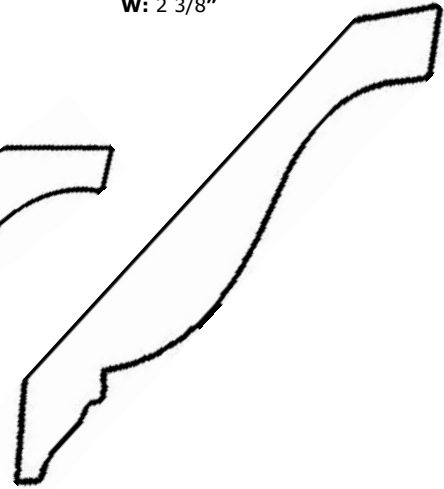

M132
H: 4"
W: 3"

Crown Moldings with Base

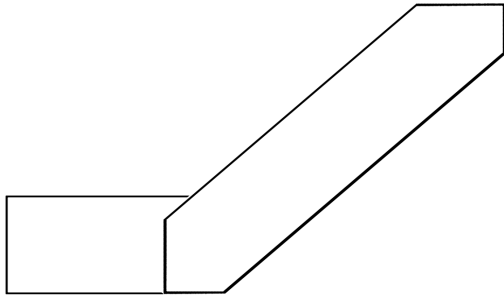

M119

H: 2 1/2"

W: 3 13/16"

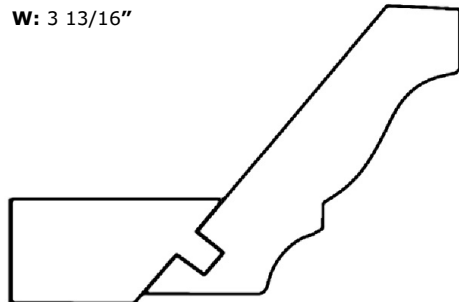

M150

H: 2 9/16"

W: 3 11/16"

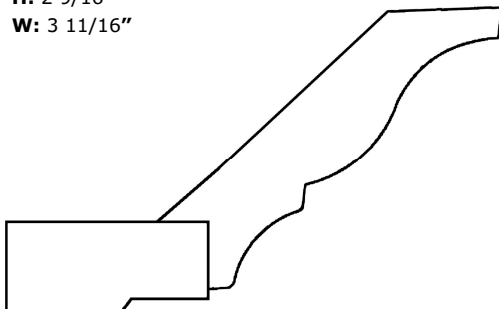

M165

H: 2 5/8"

W: 3 15/16"

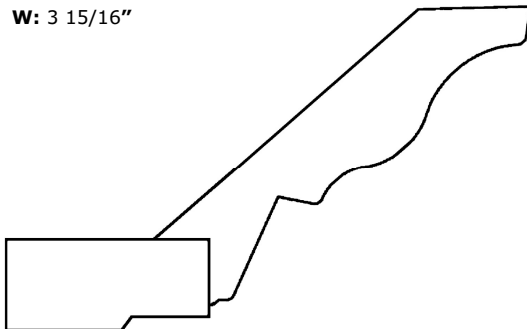

M167

H: 2 13/16"

W: 4 1/8"

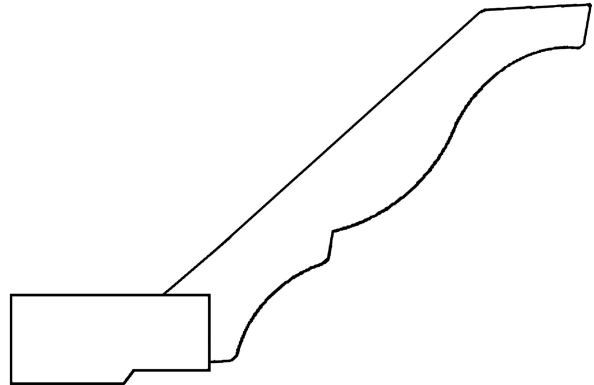

M118

H: 3 3/8"

W: 4 11/16"

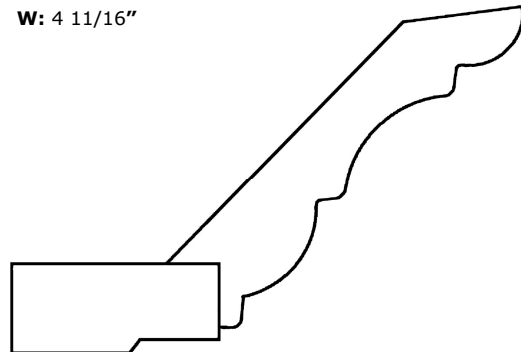

M121

H: 2 3/4"

W: 4 1/16"

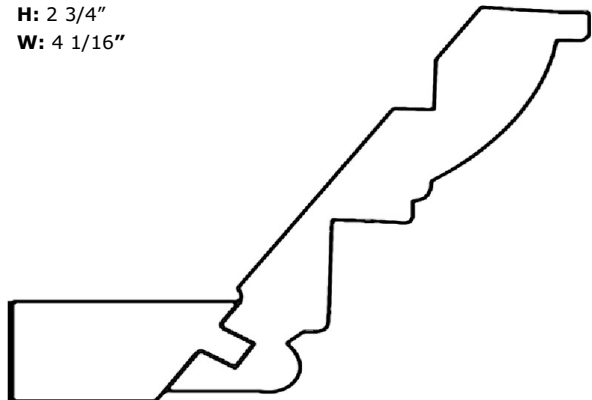

M160 *

H: 3 9/16"

W: 4 3/16"

*available with rope (M143) or dentil (M144) molding

Decorative Moldings

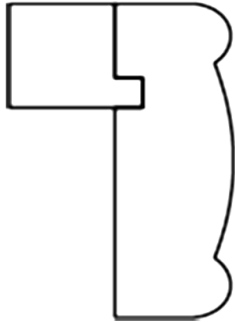

M155
H: 2 1/4"
W: 1 5/8"

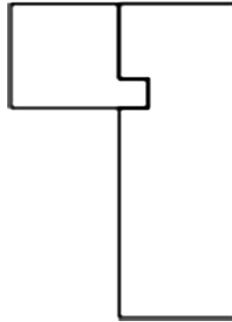

M156
H: 2 1/4"
W: 1 5/8"

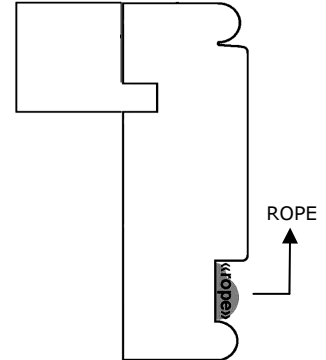

M157
H: 2 1/2"
W: 1 5/8"

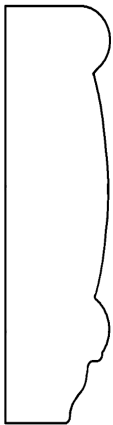

M125
H: 2 15/16"
W: 3/4"



M163
H: 3"
W: 3/4"

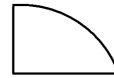

M127
H: 1/2"
W: 3/4"

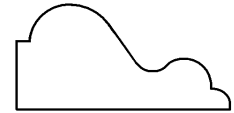

M129
H: 3/4"
W: 1 1/2"

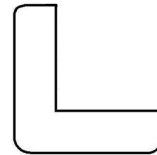

M140
H: 1 1/16"
W: 1 1/16"

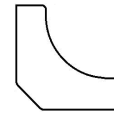

M141
H: 3/4"
W: 3/4"

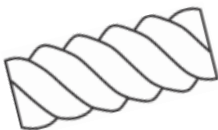

M143 Rope
H: 7/16"
W: 3/4"

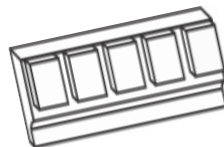

M144 Dentil
H: 7/16"
W: 7/8"

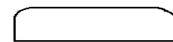

M142
H: 1/4"
W: 1 3/16"



M145
H: 5/8"
W: 1 3/8"

Accessories

Fluted Fillers

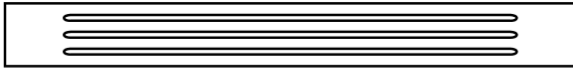

A9500

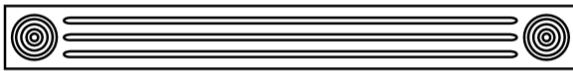

A9510

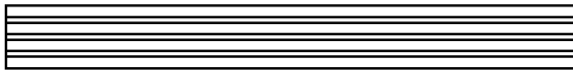

A9520

Valances



V170



V175

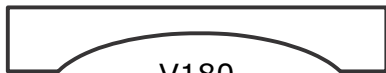

V180

Wine Racks



A9930 - 3 Holes

A9940 - 4 Holes

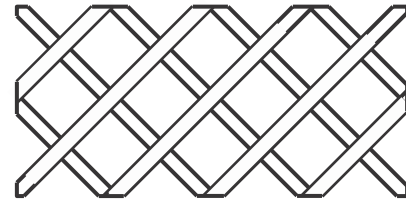

A9980 - 24" X 30"

A9990 - 17" X 36"

Dovetail Drawer Boxes

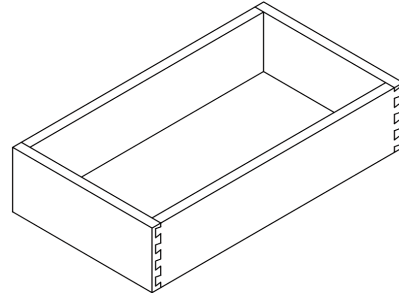

Appliance Garages

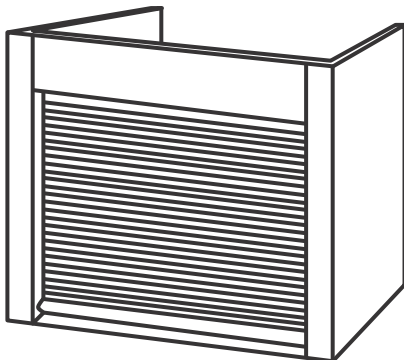

A9400

H: 18 1/2" D: 11 7/8"

W: 18", 24", 30"

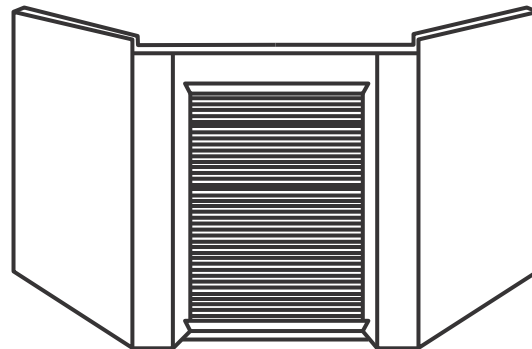

A9450

H: 18 1/2" D: 11 7/8" W: 24"



Saint-Agapit Wood Products Inc.

1269 Principale

Saint-Agapit, Quebec G0S 1Z0

Phone: 1-800-463-7461

Fax: 1-800-463-6167

www.sawpinc.com

E-mail: sawp@total.net